

# User's Guide



## *Fidji*



*Model Shown : 10110-10*



**Examination couch**  
**10110-10**

# Product Identification

*Model Number :*

*Serial Number :*

*Date of Purchase :*

*Name of Owner / Facility :*

*Name of Dealer :*

*Dealer's Phone Number :*

*Promotal Authorized Service Company :*

## **Legal Notice**

PROMOTAL  
22, rue de Saint-Denis de Gastines  
B.P. 26 - 53500 ERNÉE Cedex  
FRANCE  
Tél. : +33 (0)2 43 05 12 70  
Fax : +33 (0)2 43 05 68 99  
internet : [www.promotal.com](http://www.promotal.com)

The descriptions and specifications contained in this Operating Manual are deemed correct at the time of printing.

**Promotal**, however, reserves the right to modify its models and its procedures or render them obsolete without notice.

Before any order, we recommend that our customers consult a local sales manager.

**Type plate**

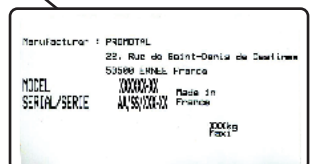

<b>Important Information</b>	<b>6</b>
<i>Safety symbols</i>	6
<b>Precautions when unpacking</b>	<b>7</b>
<i>Material delivered in cardboard packaging</i>	7
<i>Dismounted material</i>	7
<i>Storage condition</i>	7
<i>Conditions of use</i>	7
<i>Unpacking / Installation</i>	7
<i>Verification</i>	8
<b>Cleaning protocol</b>	<b>9</b>
<i>Warning</i>	9
<i>General maintenance</i>	9
<i>Disinfection</i>	9
<i>Maintenance Instructions</i>	9
<i>Painted surfaces (epoxy polyester finish)</i>	9
<i>Imitation leather coverings</i>	10
<i>Stainless steel products</i>	10
<i>Chrome finished products</i>	10
<i>PVC and ABS products</i>	10
<i>Laminated elements</i>	10
<b>User's Guide – Examination Couch</b>	<b>11</b>
<i>Intended use</i>	11
<i>Authorisation to use</i>	11
<i>Patient weight capacity</i>	11
<i>Features</i>	11
<i>Dimensions</i>	12
<b>Assembling instruction</b>	<b>13</b>
<i>Assembling the upholstery</i>	13
<i>Upholstery Backrest</i>	13
<i>Upholstery Seat</i>	13

<b>Using the Couch</b>	<b>14</b>
<b>Adjusting the backrest tilt</b>	<b>14</b>
<b>Paper roll</b>	<b>14</b>
<i>Installation of the paper roll holder</i>	14
<i>Using the paper roll</i>	15
<b>The levellers</b>	<b>15</b>
<i>Adjusting the levellers</i>	15
<b>Accessories</b>	<b>16</b>
<b>Pair of Clamps</b>	<b>16</b>
<i>Installing the Clamps</i>	16
<b>Arm rest</b>	<b>16</b>
<i>Adjusting the arm rest</i>	16
<b>Pair of stirrups</b>	<b>17</b>
<i>Installing the stirrups</i>	17
<b>Pair of legrests</b>	<b>17</b>
<i>Installing the legrests</i>	17
<b>Pair of covers for legrests</b>	<b>17</b>
<b>2 hook IV pole</b>	<b>18</b>
<i>Installing the IV pole</i>	18
<b>Auto-blocking I.V. pole</b>	<b>18</b>
<i>Installing the IV pole</i>	18
<i>Adjusting the height of the IV pole</i>	18
<b>The pair of barriers</b>	<b>19</b>
<i>Installing the pair of barriers</i>	19
<i>Using the pair of barriers</i>	19
<b>Headrest</b>	<b>20</b>
<b>Backrest extension</b>	<b>20</b>
<i>Installing the Backrest extension</i>	20
<b>Headrest</b>	<b>21</b>
<i>Installing the Headrest</i>	21
<b>Adjustable paper-roll holder</b>	<b>22</b>
<i>Installing the paper roll holder</i>	22
<i>Installing the paper roll holder [with the head-rest (ref. : 2054-01)]</i>	23
<i>Installation of the paper roll</i>	24
<b>Paper-roll holder</b>	<b>24</b>
<i>Installing the paper roll holder</i>	24
<i>Installation of the paper roll</i>	24
<b>Paper cutter</b>	<b>25</b>
<i>Installation of the paper cutter</i>	25
<i>Using the paper cutter</i>	26



<b>Options</b>	<b>27</b>
<i>Face slit in head-cushion</i>	27
<b>Lifespan of the Medical Device</b>	<b>28</b>
<i>Obligatory/specific maintenance</i>	28
<i>End of the device's useful life</i>	28
<b>Maintenance notebook</b>	<b>29</b>
<b>Warranty Information</b>	<b>30</b>
<b>Warranty</b>	<b>30</b>
<i>Obligations</i>	30
<i>Exclusions</i>	30
<i>Exclusive Remedy</i>	30
<i>No Authorization</i>	30
<b>Declaration of Conformity</b>	<b>31</b>

# Important Information

## Safety symbols



### Warning sign

The information marked with this symbol must be read and strictly followed !

### Note

Procedure, practice, or condition.



Humidity limitation



Maximum number of stacked pallets



Correct orientation for transportation



Atmospheric pressure limitation



Temperature limitation



Fragile



Keep in a dry place



Not to use sharp objects



Manufacturer



General safety sign



Refer to the instruction manual / brochure



CE marking



Do not sit on the back rest

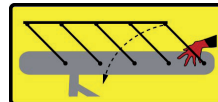

Warning :  
Pinching risk between the sides and the seat of the couch



### Warning

The warning pictograms and signs installed by the manufacturer must not be removed ! The manufacturer's responsibility is cancelled if these signals are removed.

# Precautions when unpacking

## Material delivered in cardboard packaging

*Small, lightweight, easy to handle material*

In this case, the products can be easily handled without any lifting gear, taking care to position the product according to the directional arrows on the packaging.

In the absence of arrows indicating the top and bottom, use the position of the various product identity labels which are always placed at the top.

*Heavy or cumbersome material requiring the use of lifting gear*

In this case, it is possible to use a fork lift truck, provided it is used correctly.

Before moving, ensure the material is properly positioned, and that the load is evenly balanced.

## Dismounted material

These products are delivered unassembled.

The various elements are protected by the following types of packaging :

- plastic (vinyl) packaging
- bubble film packaging / foam or polystyrene
- cardboard packaging.

## Storage condition

Ambient Temperature Range :

Relative Humidity :

Atmospheric Pressure :

The following conditions must be observed when storing any material :

- The area must be clean, well ventilated and be of a normal temperature.
- Store products away from the elements, and away from direct sunlight.
- The area must not be damp.

-15 °C to +60 °C (+5 °F to 140 °F)

10 % à 90 % (non-condensing)

0.5 bar to 1.05 bar (500 hPa to 1050 hPa)

- The products must not be subject to bumps or jolts.
- Do not store in an area where people are likely to pass.
- Articles must not be stacked on top of each other.
- Articles must remain in their original packaging until final delivery.

## Conditions of use

- Dry and temperate area.
- Maximum altitude : 2000 m

- Temperature 10 to 40° C
- Relative humidity 75% maxi.

## Unpacking / Installation

When installing, remove all staple clips and carefully remove the cardboard packaging. Fragile parts of the product (upholstery coverings, plastic casings, etc.) may be just below the packaging. Care must be taken with cutting instruments.

Once the packaging has been removed, remove any remaining protective covering.

In the case of packaging on a wooden palette, remove the packaging as above. Depending on the model, the product is fixed either by screwed flanges, or by nailed wooden stakes. Use a spanner (for metal flanges). Use a claw hammer (for wooden stakes). Lift the article off the palette, and remove the remaining protective covering. The product is now ready for use.

# Precautions when unpacking

## *Verification*

After unpacking the device, follow the steps below :

Check the delivery documents to make sure that the consignment is complete.

Check the external components and look for possible transport damage.

Check that the package contains the device, the accessories and options, the power cord (*if electric DM*) and the Operating guide.

### **Note :**

#### ***Authorized CE representative***

Countries in the EEC should direct all questions, incidents, and complaints to Promotal's Authorized CE representative listed below :

Promotal  
22, rue de Saint-Denis de Gastines  
53500 Ernée,  
FRANCE  
Téléphone : + 33 (0)2 430 517 76  
Fax : + 33 (0)2 430 572 00



## Warning

You must read the installation instructions, technical instructions, and instructions for use before handling this equipment. The instrument must be used only for the specific purpose for which it is designed, and which is described in our literature. The assembly and connection to the mains must be carried out by qualified personnel.

Under no circumstances must electrical parts (motor, unit housing the electrical control systems, control unit, adaptor etc.) be opened. PROMOTAL cannot be held responsible for any damage resulting from the instructions not being followed.



**Any modification of the DM without the manufacturer's written authorisation is prohibited.**



**Caution**  
**Only those accessories allowed and provided by Promotal for this DM may be used.**

## General maintenance

Apart from regular cleaning, our products do not require regular maintenance.

The mechanical parts used as blocking mechanisms (smooth arch, notched arch, ratchet mechanisms, etc.) do not require any specific attention. The gas springs on tables do not require any maintenance. Their shaft must be kept clean, must not be subject to jolts or hard knocks, and must not be cleaned with any corrosive products. The electric and hydraulic jacks do not require any particular attention.

The variable height tables, chairs and trolleys are equipped either :

- With arms fitted with self lubricating articulation rings.
- With telescopic bearing runners. In this case they should be lubricated once a year (particularly if the runners are noisy) with ordinary grease. (See the exploded drawings for access to the runners).

## Disinfection

This Medical Device must be regularly disinfected by products which qualify as Bactericides, Virucides and Fungicides.

## Maintenance Instructions

### *Painted surfaces (epoxy polyester finish)*

The use of ordinary cleaning products, eg. window cleaning products, is perfectly suitable for cleaning surfaces finished in epoxy polyester. **The following products are not recommended as they will damage these surface :**

#### **- Solvents :**

Petrol  
High-grade alcohols :  
- Aliphatics  
- Aromatics  
Ketones - esters  
Tri -perchloroethylene

#### **- Bases :**

10 % sodium  
10 % ammonium

#### **- Acids :**

30 % nitric  
30 % chlorhydric  
10 % citric

#### **- Others :**

Bleach  
Abrasive powders  
Any abrasive  
Cleaning product

# Cleaning protocol

## *Imitation leather coverings*

Use a damp cloth and soapy water (eg. household soap). For stubborn stains, dab, but do not rub, using a cloth soaked in white spirits or in a solution of water and alcohol (less than 30 % strength).

**It is not recommended to use the following :** Pure alcohol, acetone, perchlorethylene, trichlorethylene, all solvents and detergents, any abrasive cleaning agents, any kind of wax.

## *Stainless steel products*

**Cleaning and Maintenance :** For maintenance of stainless steel products, periodic cleaning of the surface is sufficient. This operation is necessary to keep the products clean, but is facilitated by the quality of stainless steel surfaces. A large range of products and cleaning methods may be used. The choice products method will depend on the nature of the marks or on the product content, and on the conditions of use of the stainless steel elements.

### *Cleaning agents*

**a) Detergent - washing liquids :** All types of detergents, washing liquids and commercial soaps may be used, provided they do not contain any chlorine products.

**b) Abrasive powders :** These products may scratch the stainless steel surface, thereby changing the way its appearance. They should therefore not be used.

**c) Solvent :** May be useful in getting rid of grease marks. The usual solvents (benzene, methylene chloride, white spirits etc.) as well as domestic or

**Flame retardant classification :** All our coverings class are M2 or M1. We can provide you with a manufacturers certificate on request.

specially prepared industrial products may be used. Naturally their use requires certain precautions to be taken because of their flammable and toxic properties. Precautions must also be taken to avoid damaging adjacent materials which may be sensitive to their chemical action (paints, mastics, joints etc.).

**d) Acid products :** Vinegar (acetic acid) may be used to get rid of stains made by calcium deposits. Its contact with the surfaces must be of a very limited duration, and the surface must then be thoroughly and carefully rinsed with clean water. The use of chlorine based products could damage this equipment.

**e) Bases :** Not recommended.

**Others :** The use of steel wool or metal sponges could damage the surfaces of the products.

## *Chrome finished products*

**Cleaning and Maintenance :** It is through important, in order not to damage this protective coating, abrasive and / or corrosive products the use of. The use of commercial cleaning products, such as window cleaning products, are safe for chrome coated surfaces. If necessary, an appropriate disinfectant may be used on chrome (make sure the instructions are followed).

## *PVC and ABS products*

**Cleaning and Maintenance :** The use of commercial cleaning products, such as window cleaning products, are safe for PVC and ABS surfaces. To restore up an old or dull surface, plastic restorer products may be used. Please note that the use of any solvents or any abrasive products is could damage these surfaces.

## *Laminated elements*

**Cleaning and Maintenance :** As for PVC. Use window cleaning products.



## **Intended use**

This appliance is designed for use in professional premises only :

- Medical practices
- Care establishments

This appliance must not be installed in domestic premises.

This table is designed to be used only by healthcare staff. This examining table is used to perform interventions under the best possible safety conditions.



This table is not designed to be used as a stretcher.

## **Authorisation to use**

Only health professionals (doctors, caregivers) and/or qualified members of the technical staff can handle or use the couch.

Patients and companions must not intervene directly on the couch. They must not have access to the couch controls.

## **Patient weight capacity**



## **Features**

Light grey epoxy polyester coated steel frame

Gas spring assisted backrest

Paper roll holder,

max length 50 cm - ø 20 cm (Head-end)



# User's Guide – Examination Couch

## Dimensions

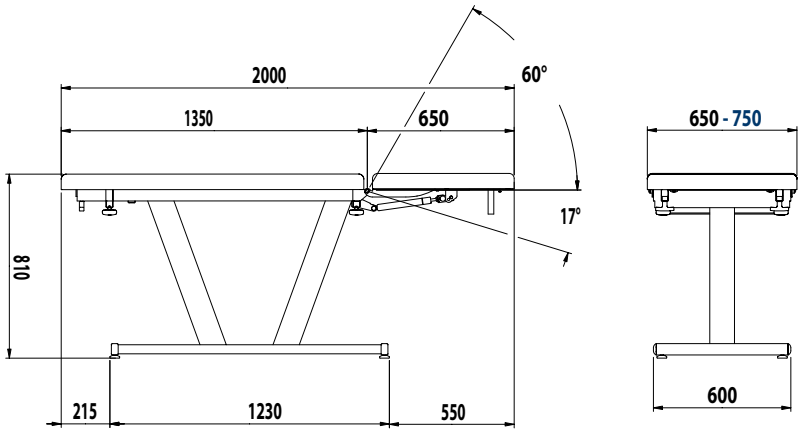

10110-10 + 600151-65



10110-10 + 600150-70



# Assembling instruction

## Assembling the upholstery

### Upholstery Backrest

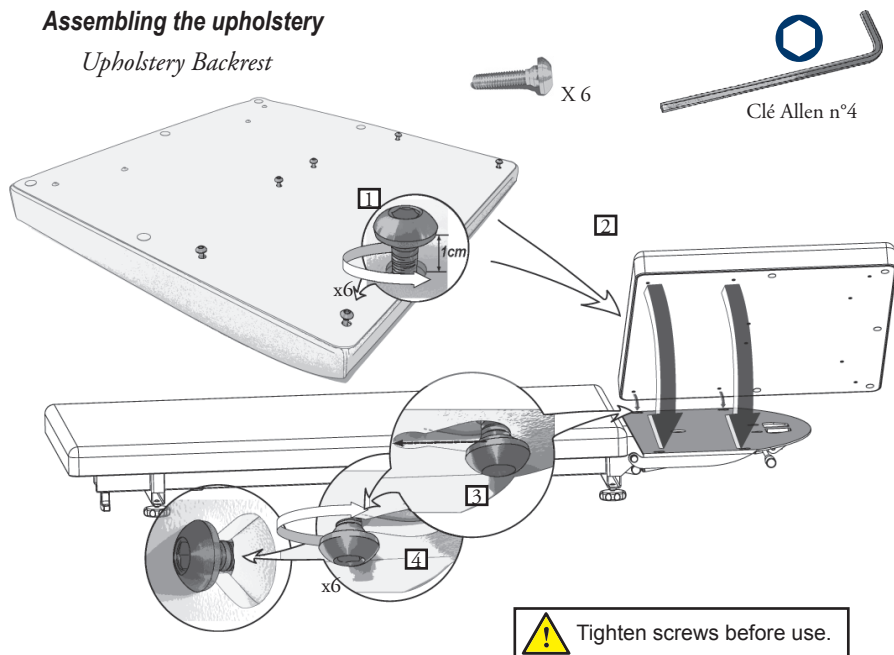

### Upholstery Seat

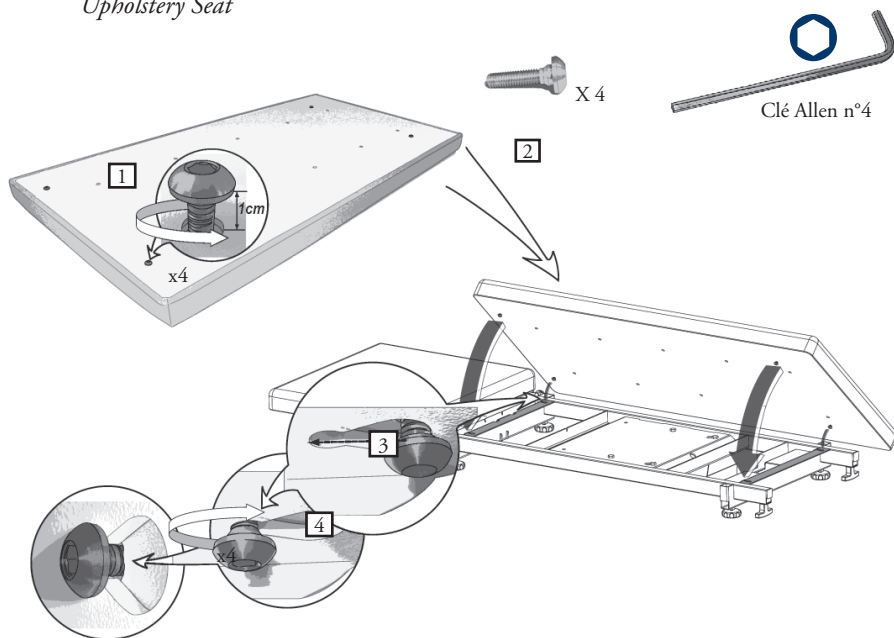

# Using the Couch

## Adjusting the backrest tilt

With one hand, move the lever (L1) either up or down, with the other hand lower or raise the backrest to the desired position.



The patient must not lean with his / her full weight on the backrest during this procedure.

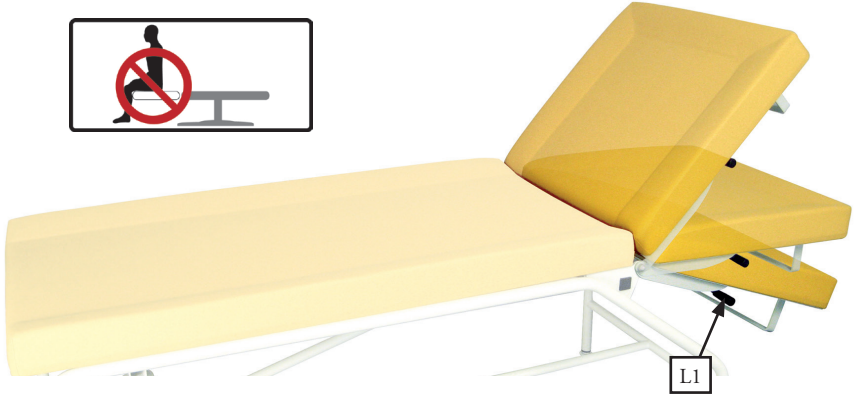

## Paper roll

*Installation of the paper roll holder*

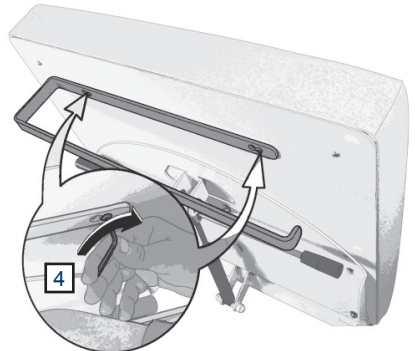
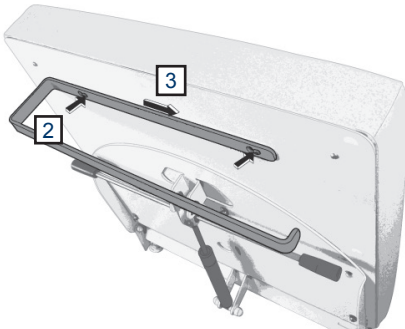
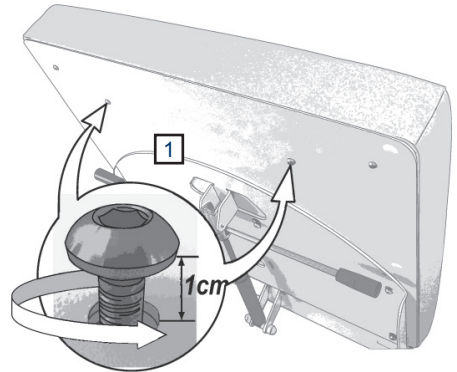
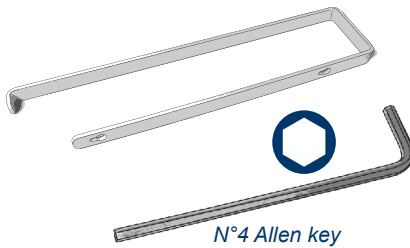

### *Using the paper roll*

Cover the upholstery with paper before use.



Caution follow the indications provided well obtain a greater longevity of the material.

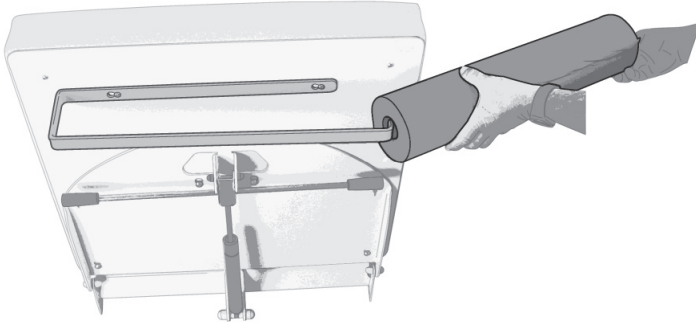

### **The levellers**

#### *Adjusting the levellers*

Screw or unscrew the leveller to the desired height.

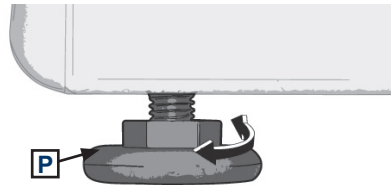

## Pair of Clamps

(reference 166)

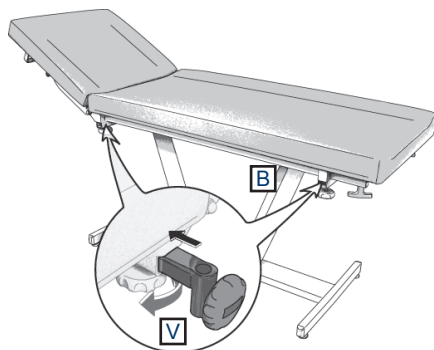

### Installing the Clamps

Take the stopper (B) out of the square tube if necessary. Loosen the nuts (V), and put the pair of clamps ref.166 (E) into position in the square tubes. Tighten the nuts.

The clamps accept accessories with a diameter of 16 mm.

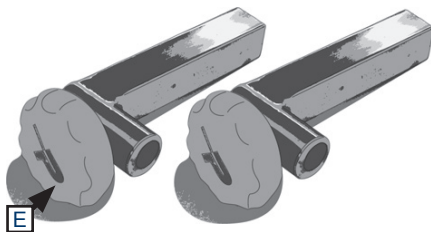

## Arm rest

(reference 2536)

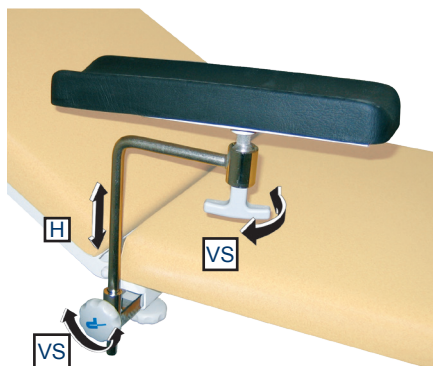

### Adjusting the arm rest

The standard arm rests can be adjusted in height (H) and can be positioned in all directions due to the ball and socket joint underneath the armrest. To adjust the armrests, loosen the screws (VS) and position as desired.



**Caution**  
Re-tighten the screws before use.



### Caution

Clamps are necessary to install these accessories.  
(réf. : 166)



## Pair of stirrups

(reference 850)

*Installing the stirrups*

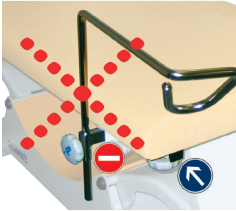

Tighten screws before use.



### Caution

Clamps are necessary to install these accessories.

(réf. : 166)

## Pair of legrests

(reference 840)

*Installing the legrests*

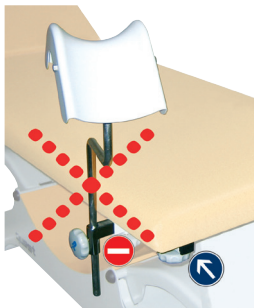

Tighten screws before use.



### Caution

Clamps are necessary to install these accessories.

(réf. : 166)

## Pair of covers for legrests

(reference 861)



## 2 hook IV pole

(reference 985-01)

*Installing the IV pole*

 Tighten screws before use.

**Caution**  
 Clamps are necessary to install these accessories.  
(réf. : 166)



*Installing the IV pole*

Unscrew the screw handle.

Insert the I.V. pole and rescrew.

**Caution**  
 Clamps are necessary to install these accessories.  
(réf. : 166)

 Tighten screws before use.



*Adjusting the height of the IV pole*

The IV pole has 1 sliding stem.  
Use the screw to adjust the height of the lower stem  
and the bolt to adjust the upper stem.



## The pair of barriers

(reference 85114-01)

### Installing the pair of barriers

1. Unscrew the screw.
2. Insert the pair of barriers. Approach the barriers to obtain a spacing of 25 mm between the barriers and the upholstery.
3. Tighten the screw.

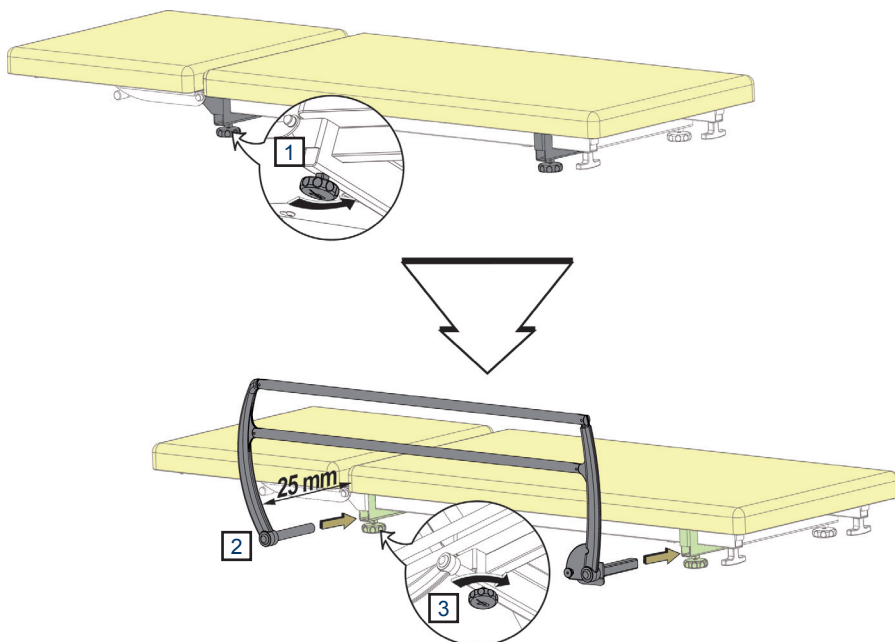

### Using the pair of barriers

#### To raise the pair of barriers

Take hold of the upper part, and lift it to its maximum height until it clicks into place.

#### To lower the pair of barriers

Hold the rail with one hand, and activate the lever (CB) to unlock the system with the other hand, then guide it down to its lowest position.

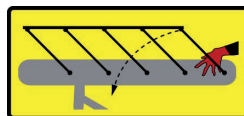
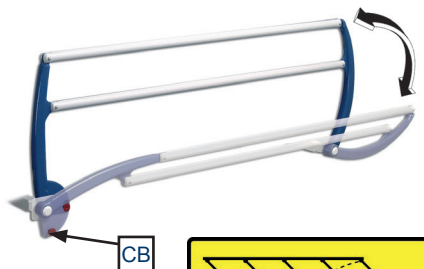

**!** Ensure the side rails are correctly locked in position before use.

# Accessories

## Headrest

(reference 1102-10)

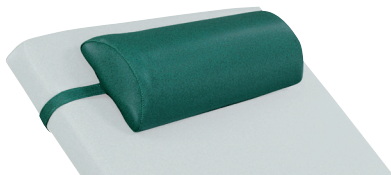

## Backrest extension

(reference 2055-01)

*Installing the Backrest extension*

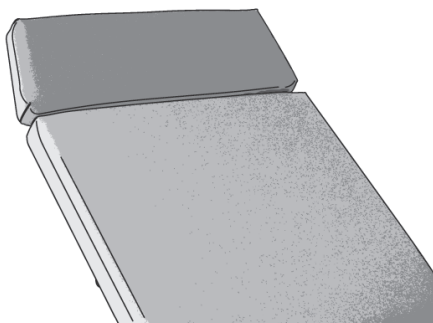
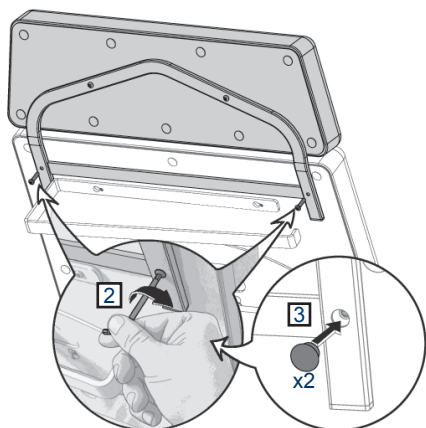
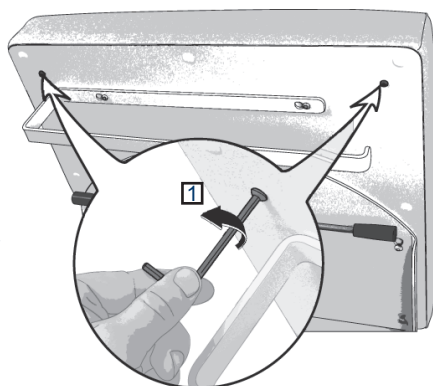
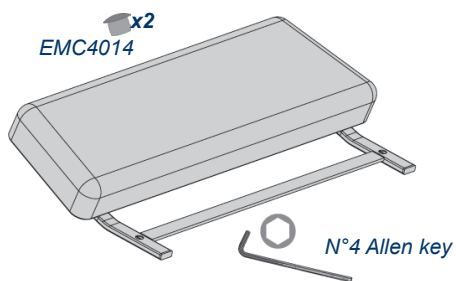

## Headrest

(reference 2054-01)

### Installing the Headrest

x4

EMC4014

A2A164-XX

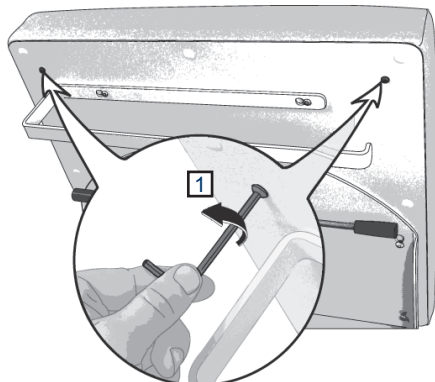
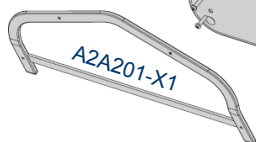

Installation of the headrest on the upholstery  
600150-65 et 600150-75

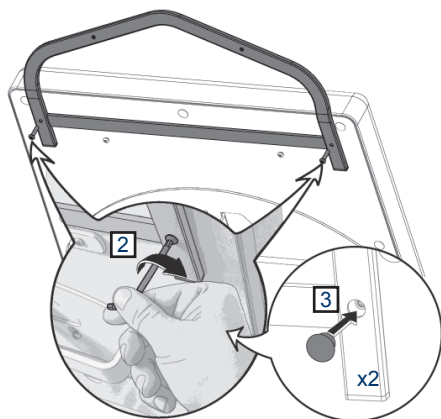

Installation of the headrest on the upholstery 600150-70

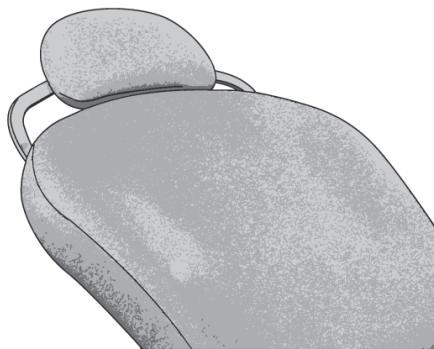
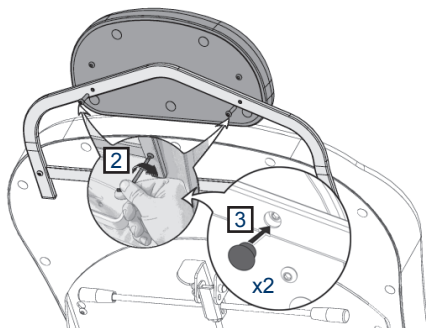
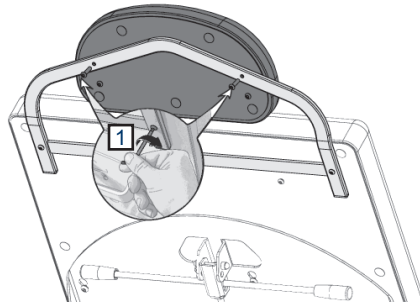

## Adjustable paper-roll holder

(reference 2056-02)

*Installing the paper roll holder*

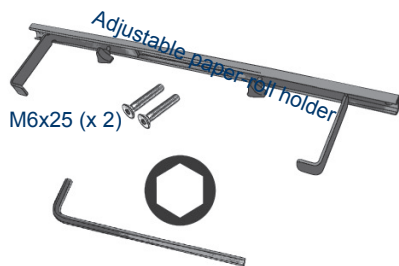

1. Remove the standard paper roll holder.

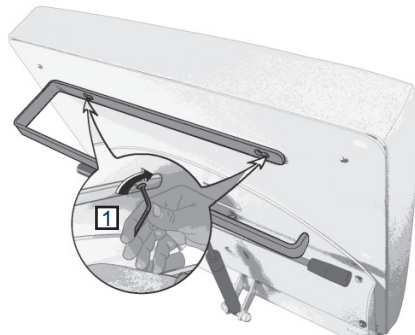

3. Replace the paper roll holder.

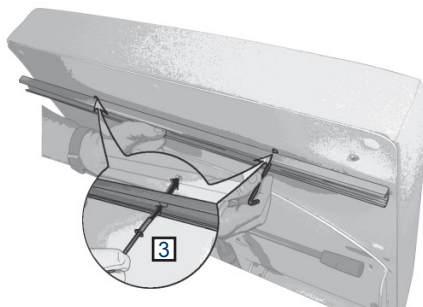
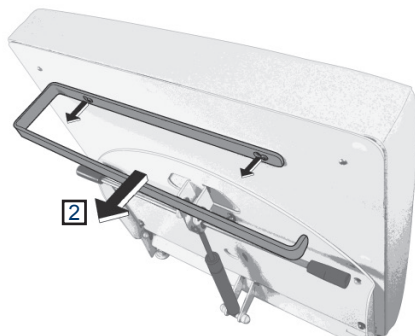

*Installing the paper roll holder  
[with the head-rest (ref. : 2054-01)]*

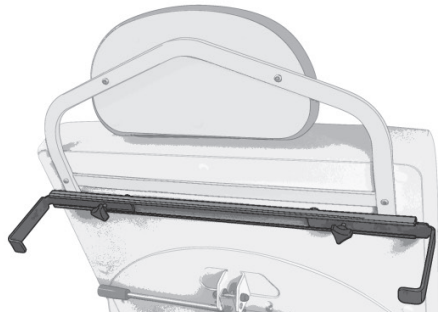
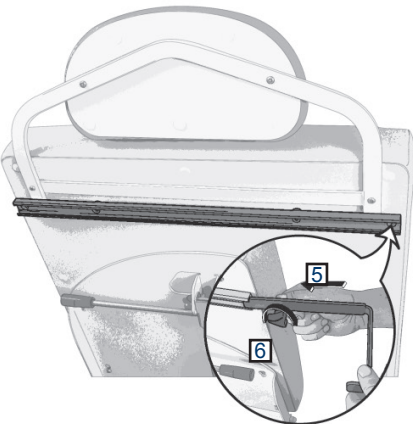
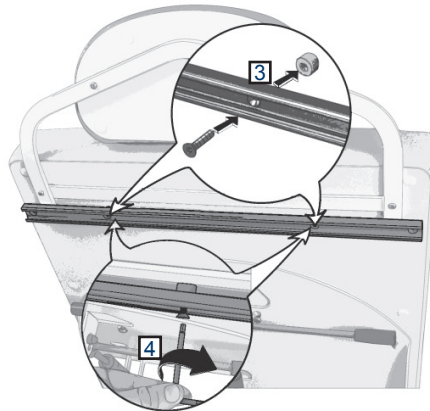
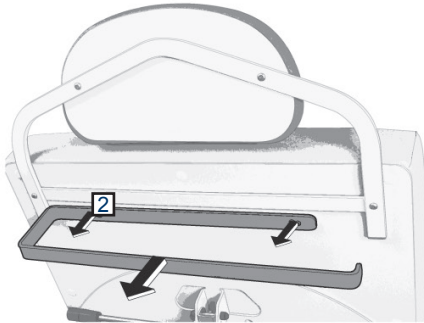
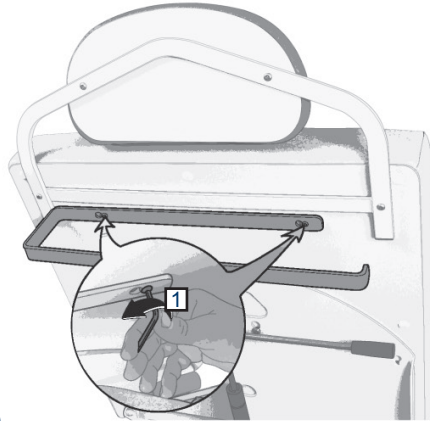
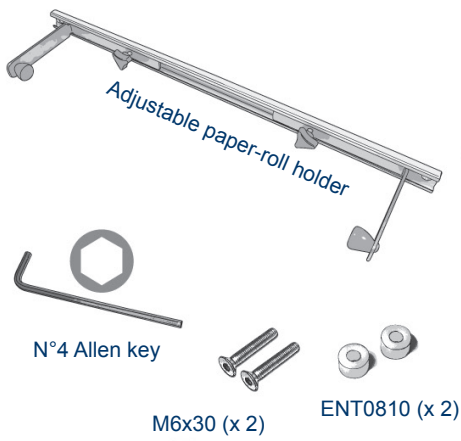

# Accessories

## *Installation of the paper roll*

The paper roll is positioned on a mobile axis with adjustable hooks at each end.

1. Unscrew the screw handle (VS).
2. To remove the paper roll holder ½ slightly (PR).
3. Insert the paper roll.

**Cover the upholstery with paper before use.**

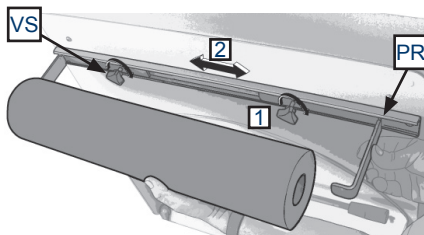

## **Paper-roll holder**

(reference 2057-02)

### *Installing the paper roll holder*

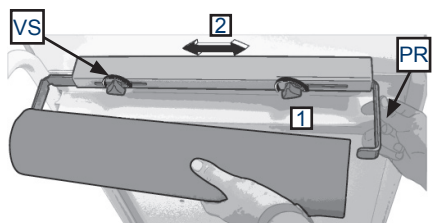
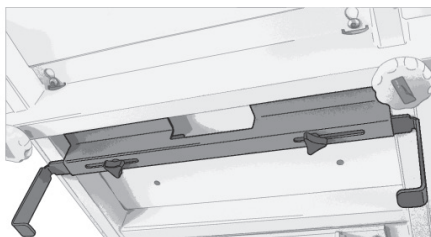
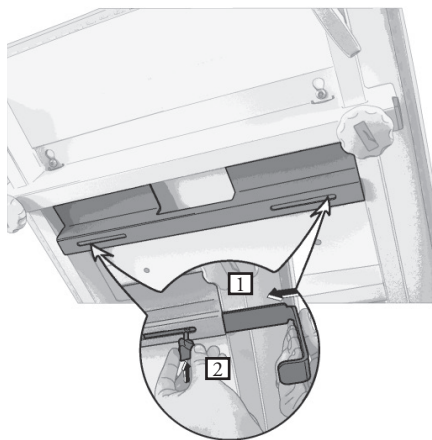
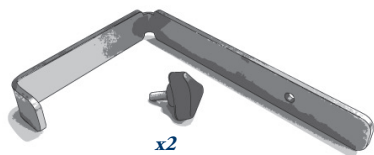

## *Installation of the paper roll*

The paper roll is positioned on a mobile axis with adjustable hooks at each end.

1. Unscrew the screw handle (VS).
2. To remove the paper roll holder ½ slightly (PR).
3. Insert the paper roll.

**Cover the upholstery with paper before use.**



## Paper cutter

(reference 2052-65 and 2052-75)

(Reference relative to the upholstery chosen 65/75 cm)

(Incompatible with upholstery 600150-70)

### Installation of the paper cutter

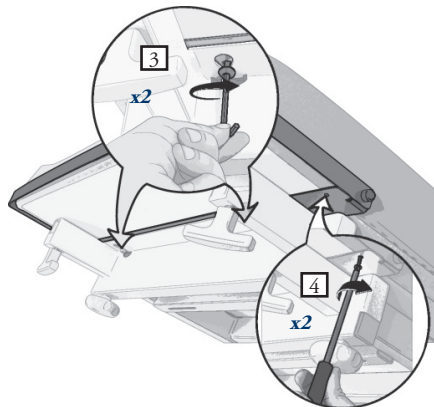
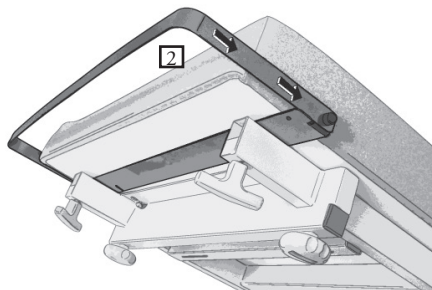
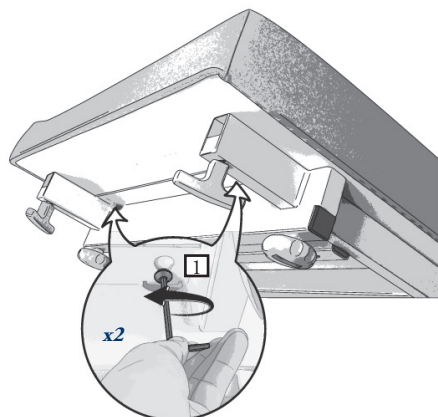
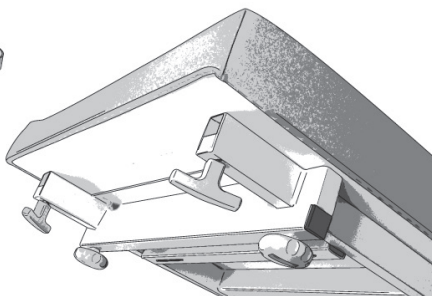
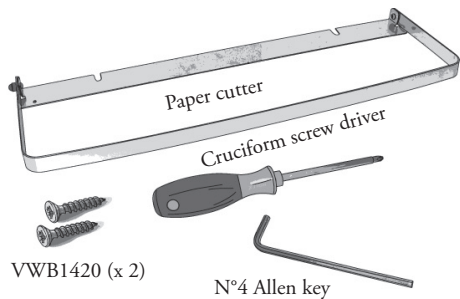

 Tighten screws before use

# Accessories

## *Using the paper cutter*

- 1) Slide the paper under the paper cutter.
- 2) Replace the paper cutter.

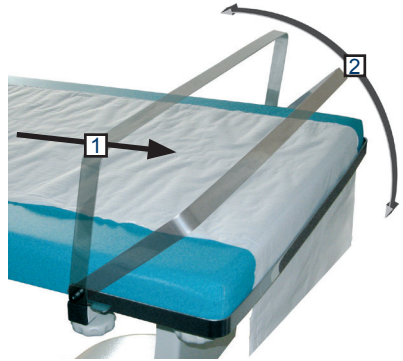

## Face slit in head-cushion

(reference 2231-65 and 2231-75)

This upholstery only corresponds to the following reference : **600150-65**  
**600150-75**

1

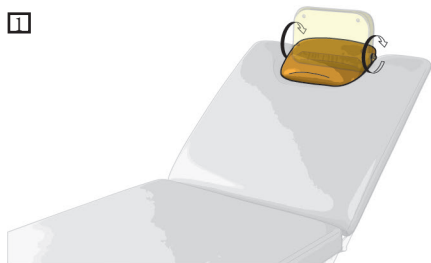

2

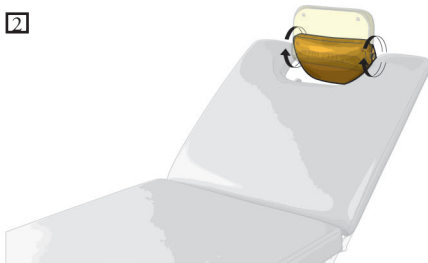

3



# Lifespan of the Medical Device

This medical device was designed for a service life of 10 years, excluding wear parts in normal working conditions. This duration may change depending on the frequency of use.

## **CHECK AT LEAST ONCE A YEAR THE GENERAL CONDITION OF THE DEVICE.**

*The wear parts are :*

- The upholstery
- The knobs and screws

Promotal recommends replacing the wear parts after a maximum of 5 years of use.

For any intervention, please contact your local authorized dealer, indicating the serial number of the device.

## ***Obligatory/specific maintenance***

*Once per year :*

- Check the screws and the rods.
- Check the articulated parts.
- Check the structure did not undergo any deformation.
- Control the various connections.
- Note this information and the date in the maintenance notebook.

## ***End of the device's useful life***

Your dealer is responsible for reclaiming and processing this device at the end of its service life.

Do not hesitate to contact Promotal, if necessary. We will suggest to you a solution to process this equipment in the best conditions.



### **Equipment warning**

All mattresses with torn covers must be promptly replaced in order to guarantee optimum functionality of this DM.



### **Material warning**

#### **Do not dismount the equipment**

If a defect is detected, immediately contact your retailer or the after-sales department of your retailer (cf Warranty Information) for a complete diagnosis. If a doubt remains, do not use the equipment.

## MAINTENANCE NOTEBOOK

Product Reference : .....  
Serial number (cf. label) : .....  
Manufacturing date (start date of warranty) : .../.../...

Date	Name of technician	Type of intervention - corrective action

**If the product is returned to the retailer or manufacturer, please clean and disinfect the material.**

# Warranty Information

## **Warranty**

Promotal warrants, to the original purchaser, products manufactured by Promotal and components to be free from defects in materials and workmanship for a period of two (2) years\* from the date of purchase.

### *Obligations*

Promotal will, at its discretion and expense, replace defective parts reported to Promotal within the applicable warranty period, and which, upon examination by Promotal, prove to be defective.

In accordance with CE regulation, Promotal's distributor is responsible for after sales service during and after the warranty period.

### *Exclusions*

- This warranty does not extend to :

- (1) Spare parts and consumables.
- (2) Travel and labour expenses.
- (3) Breakdowns due to improper use, manifest neglect, or to moving the device.
- (4) Equipment whose original characteristics have been changed by the user.
- (5) Control units, hydraulic and electric jacks if opened by the user (seals broken).
- (6) Damage, breakdowns, failures, or defects attributable to outside causes (lightning, electric surges, floods, natural catastrophes, impacts, etc.) or to the presence of foreign objects.
- (7) Damage caused by improper hook-up or by the power supply, damage caused by corrosion or by gradual deterioration of the product.
- (8) Indirect damage related to loss of use and penalties generated by poor performance.
- (9) Aesthetic damage incurred by the outside parts of the equipment, which does not hinder proper operation, such as scratches, chips, and scrapes.
- (10) Devices whose serial number has been rendered illegible or has been changed or removed

### *Exclusive Remedy*

Promotal's only obligation under this warranty is the replacement of defective parts. Promotal shall not be liable for any direct, indirect, special, incidental, exemplary, or consequential damages or delay, including, but not limited to, damages for loss of profits or loss of use.

### *No Authorization*

No person or firm is authorized to create for Promotal any other obligation or liability in connection with the products.

**THIS WARRANTY IS PROMOTAL'S ONLY WARRANTY AND IS IN LIEU OF ALL OTHER WARRANTIES, EXPRESS OR IMPLIED.**

---

\* Upholstery sets are warranted 1 year from manufacturing defaults.

# EU Declaration of Conformity

We,

**Promotal**

22 rue de Saint Denis de Gastines

53500 Ernée – France

SRN: FR-MF-000001666

declare, under our sole responsibility, that the following medical device:

Commercial name: Fidji 10110-10

Description: Examination Couch

Basic UDI-DI: 37014094BASEDIVANFIDJIYV

is a Class I medical device,

complies with the requirements of **Regulation (EU) 2017/745** of the European Parliament and of the Council of 5 April 2017,

meets the applicable European standards applicable,

bears, as such, the CE marking.

Year that the CE (Medical Devices) marking was initially affixed: 2000

Signed in Ernée,

On 26 May 2021



Rudolf MOURADIAN

Chairman

Promotal

22 rue de Saint-Denis de Gastines, 53500 Ernée, France

Tel.: +33 (0)2 43 05 17 76

Fax : +33 (0)2 43 05 72 00 [www.promotal.com](http://www.promotal.com)

EN



CE

PROMOTAL - FRANCE  
www.promotal.com  
DIC10110-10\_2121EN

